



## High Pressure Refrigerant Gauges

### Application

Standard HM8443 gauges are for refrigerant receivers rated up to 450 PSI. High pressure models of the HM8443 gauges are for refrigerant receivers rated up to 700 PSI.

The differences between the standard pressure and high pressure models are the floats and gaskets. Smaller high pressure floats are used on the high pressure models. Narrow high pressure gaskets are used on the high pressure models.

Models with visual dials are available with dials which are direct read only and dials which are direct read plus voltage output. They are available with traditional output voltages of 1-2 volts, 1-6 volts and Hall Effect dials with 0.5 to 4.5 volt output. All dials with voltage output are for use with Industrial Programmable Controllers being used in commercial/supermarket applications for continuous, repeatable measurement of refrigerant levels.

### General Information & Features

These gauges feature a 4-bolt brass head with integral mounting pads to accommodate the attachment of an electrical junction box. The junction boxes furnished with these gauges are not watertight and it is recommended that the connections inside boxes be made using waterproof connectors for rooftop and other outdoor service applications.

These gauges are typically furnished with neoprene gaskets which are compatible with several commonly used refrigerants and lubricants. Other gasket materials may be available.

The dials furnished with these gauges are magnetically driven. This means that the dials may be removed and replaced by removing two #6-32 screws and without disturbing the four gauge mounting bolts and releasing receiver contents.

The dials on gauges originally equipped with direct read or direct read plus voltage output are typically interchangeable. In other words, a 1-2 volt output dial could be replaced with a 0.5 to 4.5 volt Hall Effect dial by removing only two #6-32 screws.

Hall Effect dials with 0.5 to 4.5 volt output introduce previously unavailable levels of noise free reliability and longevity. All dials with direct read only and direct read with voltage output are for use in both indoor and outdoor locations.

### Switch Gauges

Similar gauges are available as switches only. The switch gauges have no visual gauge readout. Switch dials are replaceable but not interchangeable with direct read dials. These switches operate on line voltage and are designed for indoor locations unless all connections are protected from water.

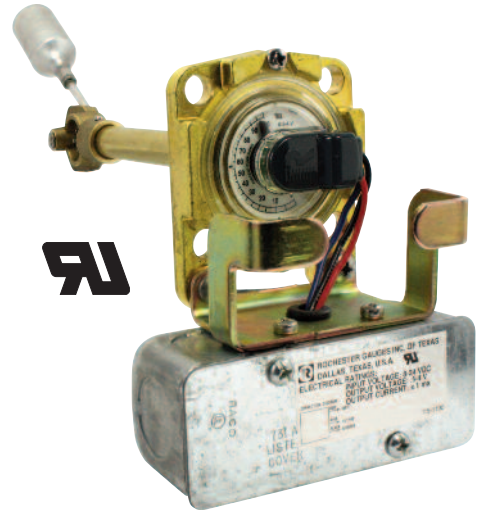

\* Materials and specifications are subject to change without notice.  
Pressure ratings subject to change due to temperature and other environmental considerations.

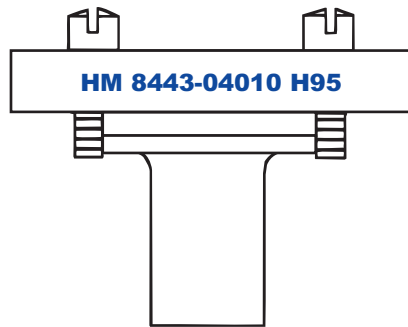

Typical gauge head showing part number and date code stamped on flats.

## General Specifications\*

### Temperatures

Standard range is -40°F to 158°F, -40°C to 70°C.

### Mounting

Rochester Senior adapter (typically part # 0022-05200).

### Working Pressure

700 psig [48 Bar].

### Approvals

UL recognized refrigeration component.

## When ordering, specify:

1. Complete part number of gauge required.
2. For replacement gauges, information stamped on the gauge head (see example above).
3. Part number of gasket desired.

**Note:** For installation instructions see MS-501/502.  
Gasket guide 115-774 available upon request.

## Materials of Construction\*

### Head

Brass forging

### Junction Boxes & Covers

Plated steel

### Centershaft, Centershaft Bearings, Pinion & Sector Gears, Cross Stud & Bearing

Stainless steel

### Gear Housing

Brass forging

### Support

Brass

### Float Rod

Tempered aluminum

### Float Bulb

One-piece aluminum

### Magnet

Alnico

### TwinSite® Sender

Polycarbonate, ultrasonically welded and hermetically sealed.

### Mounting Bolts & Dial Screws

Stainless steel

### Gasket

<b>Choice of:</b>	Neoprene	0015-01008 (standard)
	Buna-N	0015-01010 (optional)

\* Materials and specifications are subject to change without notice.  
Pressure ratings subject to change due to temperature and other environmental considerations.

12/08/2016